

This conversion kit will reduce the slot produced on a standard rail and stile router bit set from 1/4" to the desired plywood panel thickness of 5.2mm or 5.5mm.

Included items:

- (1) 5.2mm Slot Cutter or (1) 5.5mm Slot Cutter
- (1) 8mm Slot Cutter

Tools required:

- 1/2" wrench or pliers
- Rag, to grip the router bit

Step 1: Loosen the nut on the profile bit.

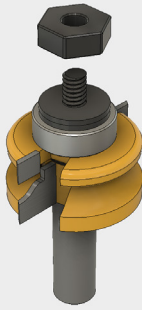

Wrap a rag around the router bit to protect your hand and provide a solid grip. Loosen the nut at the top of the bit with a wrench or pliers.

Step 2: Remove the profile bit components.

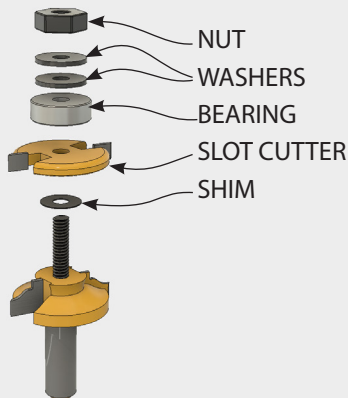

Remove the nut, washers, bearings, shims and slot cutter from the bit. Check the bottom of the slot cutter to make sure that no shims are adhered to it.

Step 3: Install the thinner slot cutter.

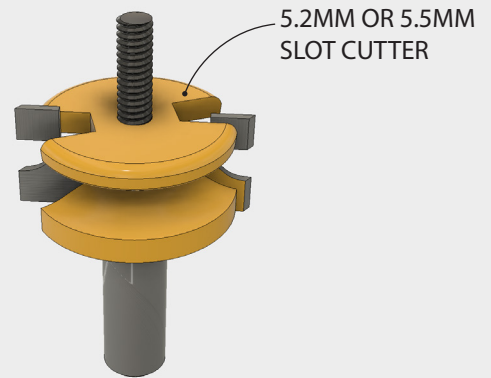

Place the 5.2mm or 5.5mm slot cutter on the bit's arbor, followed by the remaining components (the shims, bearings, washers and nut). Tighten the nut with the wrench or pliers.

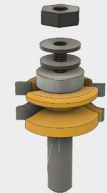

Step 4: Remove the slot cutter from the coping bit.

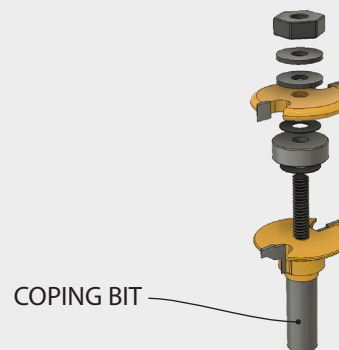

Grip the coping bit with a rag to protect your hands and loosen the nut with a wrench or pliers. Remove the nut,

washers and the slot cutter. Once again, make sure none of the shims are adhered to the bottom of the cutter.

Step 5: Install the 8mm slot cutter.

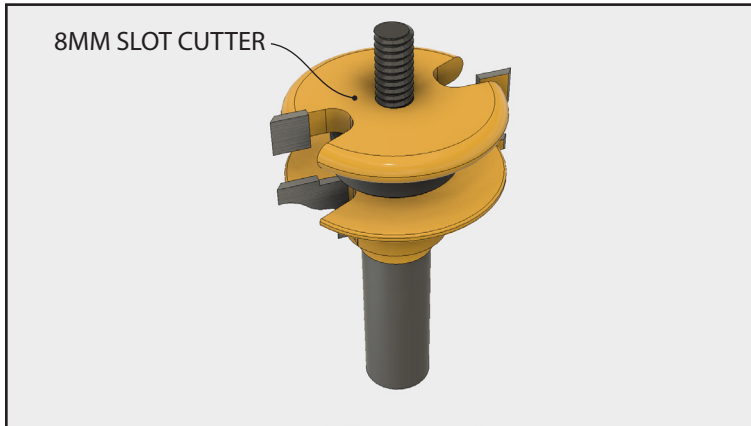

Place the 8mm slot cutter on the bit's arbor and stack the shims, bearing, washer and nut on top. Tighten the nut with the wrench or pliers.

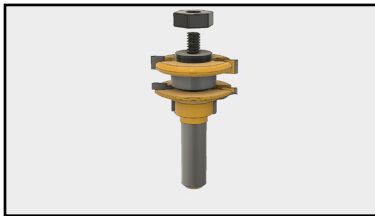

Step 6: Make sure the profile and coping bits match.

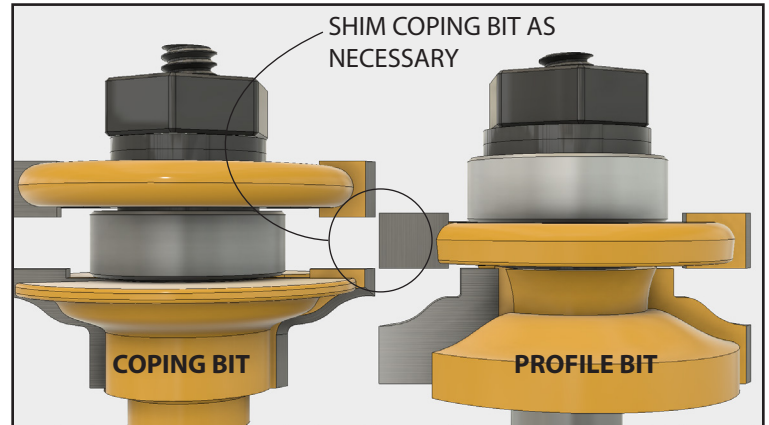

Place the two bits next to each other to check the fit. You may need to remove one or more shims to achieve a perfect fit.

Note: This kit is only compatible with rail and stile router bits with an overall diameter of 1-5/8".